

**Dry Break Quick Release Self-Sealing Couplings** are designed for use where it is necessary to connect and disconnect hoses and pipelines under pressure, quickly and without spillage.

They are used for the safe transfer of a diverse range of petroleum products and other liquids, for road and rail tank car loading and off-loading, quayside and offshore bunkering and hose exchange installations in lube oil plants etc.

Dry break couplings are available in the following bore sizes:- 3/4", 1", 1.1/4", 1.1/2", 2", 2.1/2", 3", 4" and 6"

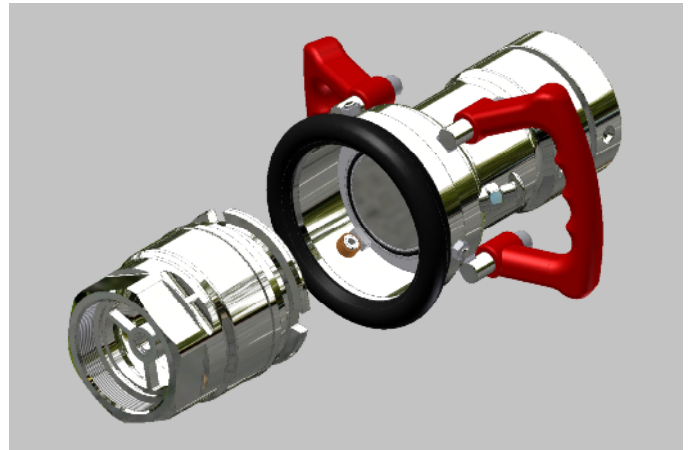

**Working Pressure 10 Bar (150 psi).**

A complete coupling consists of both a Tank and Hose unit.

The Tank unit comprises a body (either flanged or screwed), with a self sealing spring loaded valve, the Hose unit comprises a cam operated self sealing valve assembly, fixed guide sleeve and a swivel hose connector.

Operation.

The principle of operation is identical for all sizes of coupling.

Coupling operation is by a push and turn action which causes three rollers in the Hose unit to engage with the Tank unit, thus locking and sealing the two halves together, further rotation causes the Hose unit valve to open, allowing flow to commence with minimum pressure drop.

On disconnection, the two halves fully close before the couplings separate and spillage is therefore negligible (max 2cc).

To avoid service cross contamination, the coupling halves can be supplied c/w a non interchangeability feature. Both Hose and Tank units are available with BSPP and NPT female threads and the tank unit is also available with integral flange.

Materials: Aluminum, Gunmetal and Stainless Steel 316.

Viton seals fitted as standard, alternatives available on request.

